

1

INSTRUCTIONAL & MAINTENANCE MANUAL



CONTACT NOW 24/7

780.462.1910



info@weirconcepts.com



WEIR CONCEPTS INC.

WC-YS HYDRAULIC ACTUATOR

7596 Wagner RD NW Edmonton , Alberta CANADA T6E 5B2

780.462.1910 ph 780.462.1959 fax info@weirconcepts.com www.weirconcepts.com



MADE IN ALBERTA, CANADA PRODUCTS

Manufactured and assembled at our Edmonton based facility

DETAILS ARE THE DIFFERENCE BETWEEN ORDINARY AND EXCELLENCE

1. Summary

The instruction manual for YS series scotch yoke Hydraulic actuators for YS10 through YS60 model actuators.

2. Technical & Application Data

Standard temperature actuator: -40°C to +93°C

Hydraulic Input Pressure Range: 0-5000 psi

Output Torque: 12,581-6,000,000 in-lb

Operating Media: Hydraulic Fluid

3. Handling and Lifting

NOTE: Only trained and experienced personnel should handle/lift the actuator

3.1 Lifting Recommendations

3.1.1 Use industry standard practices as it pertains to suitability rated lifting devices, slings and chains that are safe for use.

3.1.2 Do not lift the actuator and valve combination using the actuator lifting lugs only.

3.2 Lifting Instructions

3.2.1 Prior to lifting the actuator remove electrical power and hydraulic lines to ensure that the actuator is fully depressurized and powered down.

3.2.2 Use only main lifting lugs.

3.2.3 Actuator must remain horizontal with the load balanced.

4. Installation on the Valve

4.1 Actuator to be installed on valve directly using the actuator housing flange or more commonly using a mounting bracket and coupling with applicable fasteners.

4.2 Actuator is supplied in the fail position (for single-acting). Install the valve in the correct position per the actuator fail position. Check the position of the actuator using position indicator on actuator body or limit switch (if applicable).

CALL US TODAY 24 hours a day, 7 days a week

4.3 Ensure the mounting faces and all connection surfaces on the valve and actuator are clean and free of any debris.

4.4 Grease the coupling stem, bore and valve stem to facilitate assembly.

4.5 Lift the actuator according to handling and lifting instruction (Section 3).

4.6 Whenever possible, install with valve stem in a vertical position.

4.7 Do not exert additional force while installing the coupling or actuator onto the valve.

5. Removal from Valve

5.1 Eliminate electrical power supply and Hydraulic supply.

5.2 Release all pressure from controls and remove supply piping/wiring.

5.3 Prepare actuator for lifting following guidelines in Section 3.

5.4 Remove all mounting fasteners.

5.5 Lift and remove actuator from valve.

6. Tube & Fitting Installation

6.1 Tubing & Fitting installation shall be performed by trained personnel using industry best practices.

Accessories Mounting Pads & Dimensions

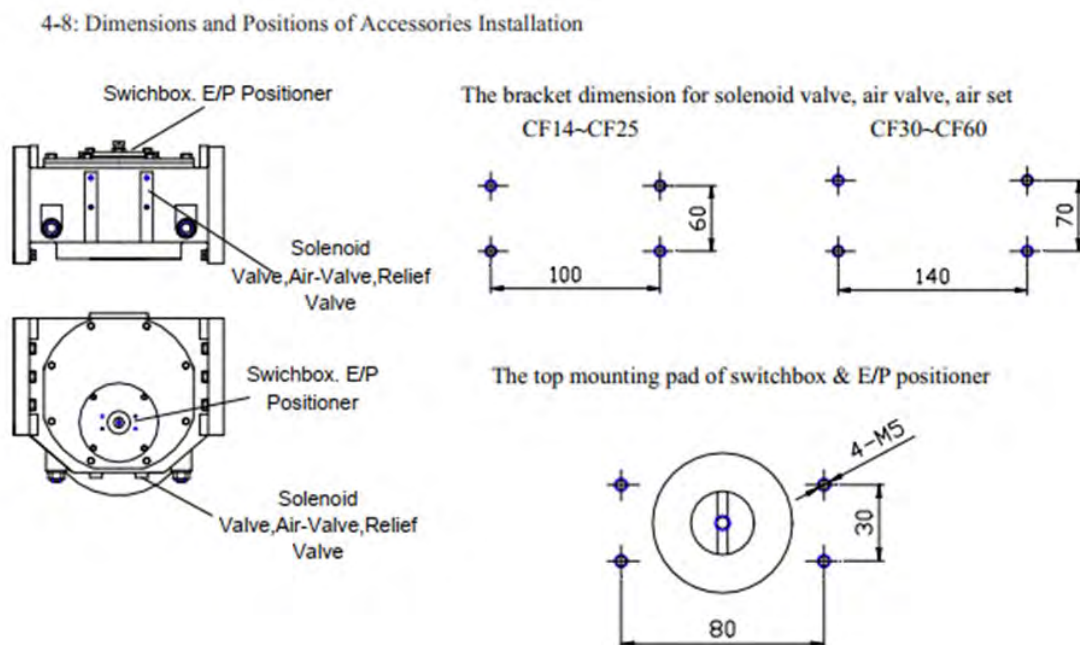

CALL US TODAY 24 hours a day, 7 days a week

7. Operation

7.1 Auto-Operation

On/Off Control Hydraulic Actuated Valve:

- A) Valve opens when solenoid valve is energized (Fail Close Type).
- B) Valve closes when solenoid valve is de-energized (Fail Close Type).
- C) Valve closes when solenoid valve is energized (Fail Open Type).
- D) Valve opens when solenoid valve is de-energized (Fail Open Type).

Modulating Control Hydraulic Actuated Valve:

4-20mADC signal to Electro-Pneumatic positioner (or 0.02~0.1Mpa to Pneumatic – Pneumatic positioner) the valve position is proportionally controlled by the input signal.

7.2 Manual Override Option

7.2.1 Double Acting Hydraulic Actuator: declutchable worm gear manual override is used for YS double acting Hydraulic actuators.

(Refer right side figure 1).

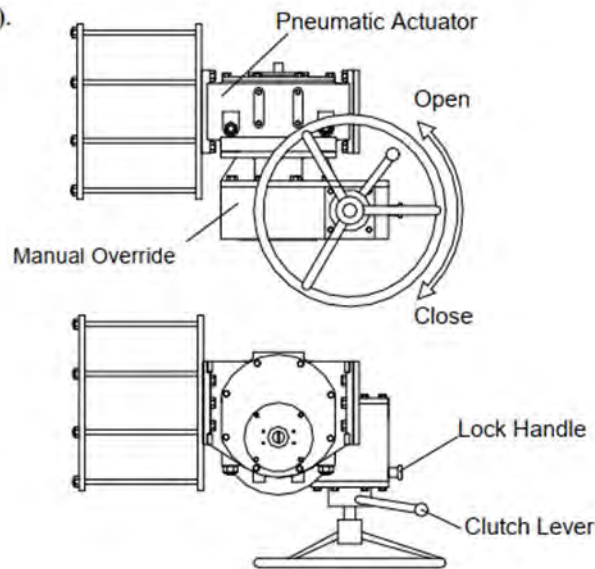

Release Hydraulic pressure. Operate worm gear as follows:

- 1) Pull out the locking handle.
- 2) Rotate the clutch lever in anti-clockwise direction until engagement takes place.

To return the automatic mode:

- 1) Pull out the locking handle.
- 2) Rotate the clutch lever in clockwise direction until engagement takes place.

CALL US TODAY 24 hours a day, 7 days a week

7.2.2 Hydraulic Manual Override

The hydraulic manual override is an integral device which consists of a manual pump, tank, globe valve and check valve. The major parts as follows:

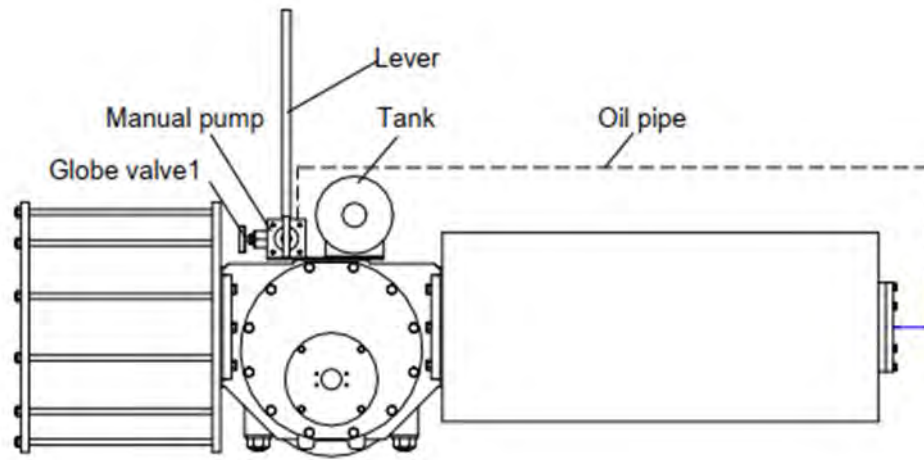

The Operation of Hydraulic Manual Override:

- a) Close globe valve.
- b) Pump using lever handle until valve cycles as required.
- c) When returning to Auto-Operation: Open the globe valve to return to fail position.

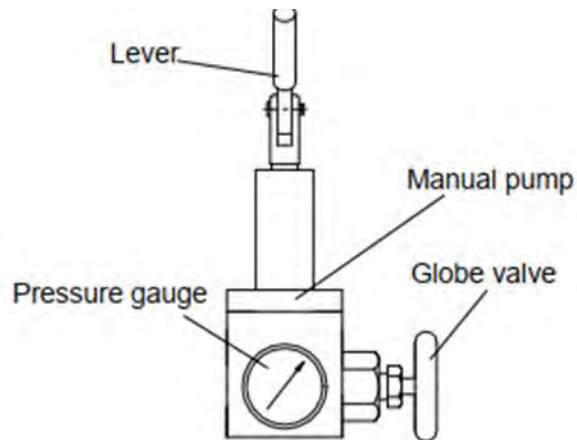
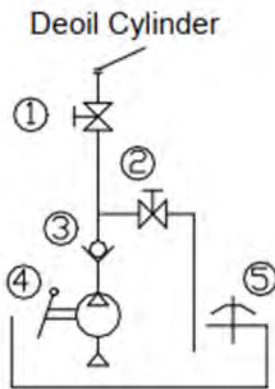

NOTE:

Do not rotate the handwheel or operate lever if the manual override is not required or engaged.

CALL US TODAY 24 hours a day, 7 days a week

8. Stroke Adjustment

The stroke adjustment is available from 80° to 100° of travel by adjusting the open and close position bolts as per below:

Loosen Nut on the open/close bolt

Adjust as needed:

Loosen = Increase travel

Tighten = Decrease Travel

Tighten Nut on the open/close bolt to set the position

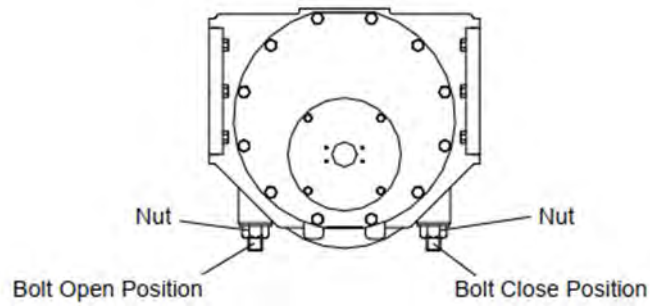

CALL US TODAY 24 hours a day, 7 days a week

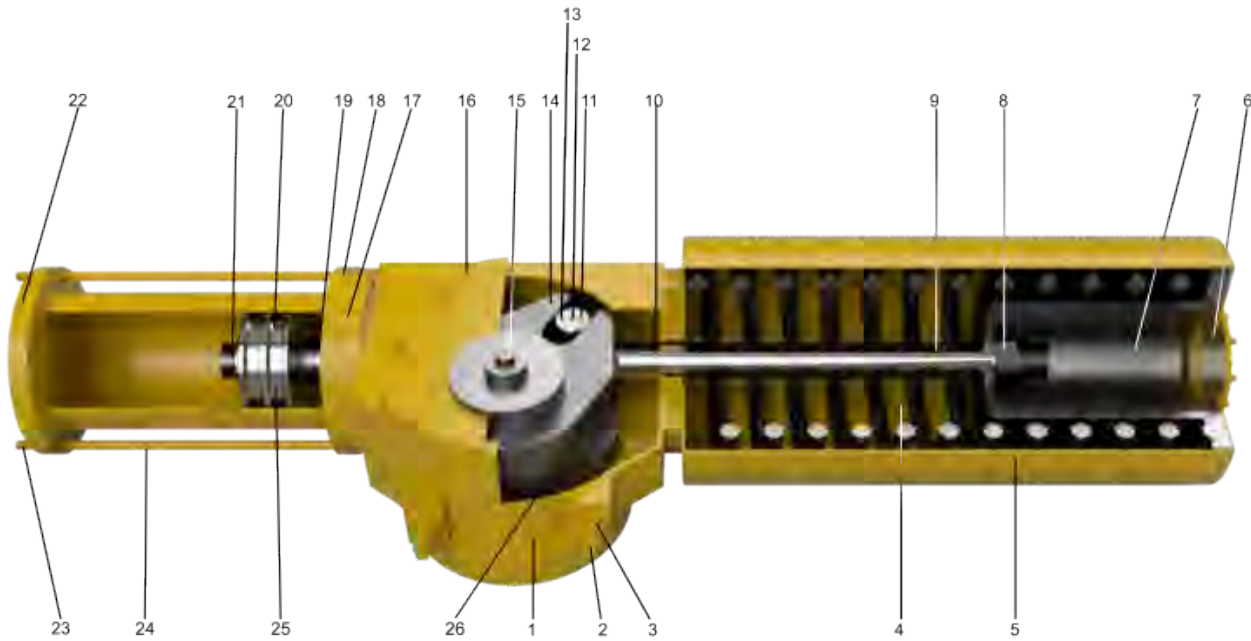

No.	Name	Material
1	Body	Ductile Iron
2	Adjust Stud	Alloy Steel
3	Nut	2H
4	Spring	Alloy Steel
5	Spring Case	Carbon Steel
6	Cover Plate	Carbon Steel
7	Spring Seat	Carbon Steel
8	Nut	2H
9	Tension Rod	Alloy Steel
10	Sliding Bearing	Metal +TFE
11	Roller	Alloy Steel
12	Slider Bearing	Metal +TFE
13	Pin	Alloy Steel
14	Yoke	Carbon Steel
15	Drive Shaft	Alloy Steel
16	Body Cap	Ductile Iron
17	Bolting	Carbon Steel
18	Adapter plate	Ductile Iron
19	O ring	NBR
20	Piston	Ductile Iron
21	Nut	2H
22	End Cap	Ductile Iron
23	Nut	2H
24	Body Screw	Alloy Steel
25	Oring seals	NBR
26	Guide Block	Ductile Iron

CALL US TODAY 24 hours a day, 7 days a week

9. Overhaul (including Seal Replacement)

NOTE: To perform disassembly of the actuator, it is preferred for it to be fully removed from the valve. Work should only be performed by experienced personnel.

9.1 Disassembly

9.1.1 Ensure actuator is fully de-energized of power and hydraulic supply and all controls removed with actuator returned to fail position.

9.1.2 Fully back off all spring stop screws. Unscrew and remove hydraulic piston end nuts from Body Screws.



CALL US TODAY 24 hours a day, 7 days a week

9.1.3 Remove the End plate and piston housing.

9.1.4 Remove all Piston O-Rings and Seals and clean all sealing surfaces. Replace all O-Rings using Weir Concepts factory seal kit. Grease O-Rings and sealing surfaces prior to re-assembly.

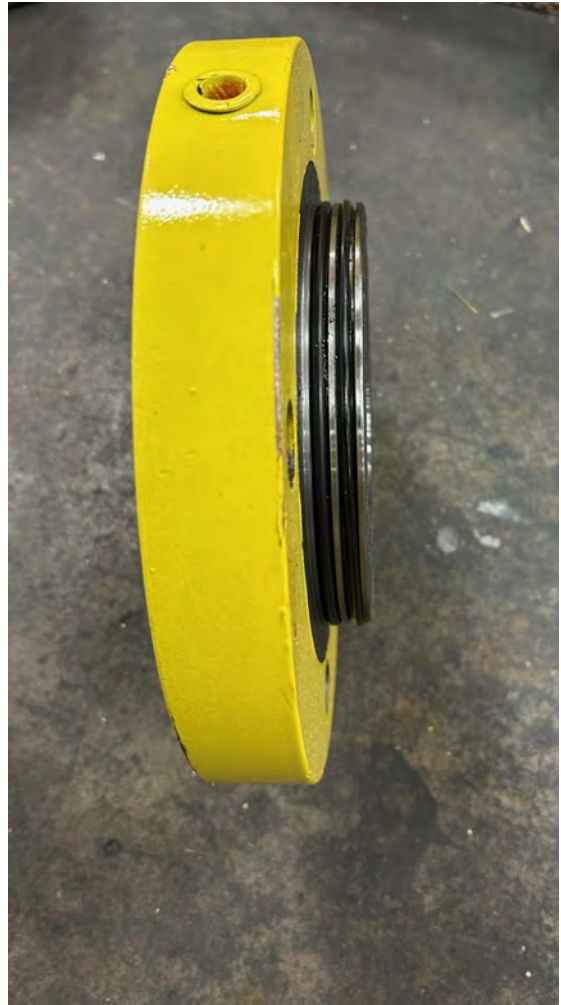

9.1.5 Reinstall piston housing, taking care to not cut or pinch any of the O-Rings. Reinstall cover plate and end nuts onto body screws and tighten evenly.

9.2.5 Connect hydraulic supply to ensure the actuator has no leaks and cycles properly.

CALL US TODAY 24 hours a day, 7 days a week

10. Troubleshooting

Issue	Possible Cause(s)	Corrective Action
Actuator not functioning	Insufficient supply pressure	Ensure supply pressure is sufficient as per catalog to cycle actuator.
	Loss of control power	Ensure power is live at source and at solenoid/positioner.
	Mechanical function of valve or actuator	If both supply pressure and control power are sufficient consult valve manufacturer and Weir Concepts service to perform further troubleshooting.
Valve not fully stroking	Stops incorrectly set	Re-adjust stops as outlined in Section 8
	Lack of supply pressure	Ensure supply pressure is sufficient as per catalog to cycle actuator.
	Valve blocked or unable to fully stroke	Consult valve manufacturer
Valve Leakage	Stops incorrectly set	Re-adjust stops as outlined in Section 8
	Valve seat or seal issues	Consult valve manufacturer
Actuator Leakage	Worn Seals	Contact Weir Concepts
	Loose or improper connections	Ensure all supply fitting connections are sufficiently tight and correctly sealed
Actuator Cycle Time too fast/slow	Incorrect supply pressure	Ensure supply pressure is correct for application as per catalog info.
	Controls adjustment required	Ensure any regulators, speed controls, etc. are adjusted correctly to achieve desired open/closing times.

CALL US TODAY 24 hours a day, 7 days a week

INSTRUCTIONAL & MAINTENANCE MANUAL WC-YS HYDRAULIC ACTUATOR



CONTACT NOW 24/7

780.462.1910



info@weirconcepts.com



- HELP DESK -

FOR YOUR SUPPORT AND SERVICE

NO CHARGE ON CALLS SERVICE

We offer technical assistance, product knowledge, and reliable trouble shooting

Brochures/Maintenance info available online www.weirconcepts.com

HELP DESK EXPERTISE PROVIDED AT WEIR CONCEPTS

7596 Wagner RD NW Edmonton , Alberta CANADA T6E 5B2

780.462.1910 ph 780.462.1959 fax info@weirconcepts.com www.weirconcepts.com



MADE IN ALBERTA, CANADA PRODUCTS

Manufactured and assembled at our Edmonton based facility

DETAILS ARE THE DIFFERENCE BETWEEN ORDINARY AND EXCELLENCE