

WEIR CONCEPTS INC.

PRODUCT GUIDE

- WCM₁₀ INLINE CHOKE -

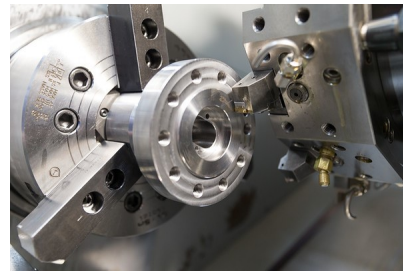
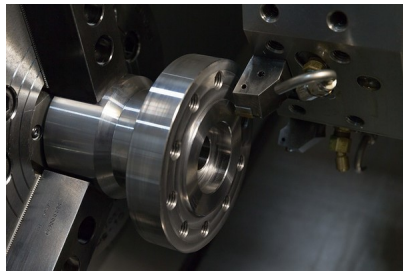

EXPECT QUALITY AND RELIABILITY

using our brand name WCM₁₀ INLINE CHOKE



Manufactured at Weir Concepts Inc.



7596 Wagner RD NW

Edmonton , Alberta

CANADA T6E 5B2

780.462.1910 ph

780.462.1959 fax

info@weirconcepts.com

www.weirconcepts.com



MADE IN ALBERTA, CANADA PRODUCTS

Manufactured and assembled at our Edmonton based facility

DETAILS ARE THE DIFFERENCE BETWEEN ORDINARY AND EXCELLENCE

**PROUDLY MANUFACTURED
AT OUR EDMONTON
BASED FACILITY**



**MAJOR BENEFITS USING THE
WCM10 INLINE CHOKE**

- MULTIPLE ORIFICE INLINE CONFIGURATION VALVE DESIGN FOR LINEAR CONTROL AND MINIMUM PRESSURE DROP AT FULL OPEN POSITION
- COMPLETE RANGE OF MATERIALS/TRIMS TO FIT MILD TO HOSTILE FIELD ENVIRONMENTS
- FLANGED OR THREADED CONNECTION
- EASILY ADAPTED TO AUTOMATION
- LONG LASTING SERVICE LIFE
- TROUBLE FREE MAINTENANCE

**FACE TO FACE DIMENSIONS MATCH
STANDARD BALL VALVE DIMENSIONS**



**Solutions for your
company needs**

WCM10 INLINE CHOKE FEATURES

- Differential pressure across the discs holds them together tightly with no loose or unsupported parts to vibrate or fatigue.
- Discs wipe clean as they rotate.
- Reversing the front and back discs creates a second set of wear edges to almost double service life.
- No interfacing shape in the center of the flow area means less wear on throttling and shut off areas. Resulting in an increase in service life and decrease in down time caused by maintenance
- Fewer parts simplify disassembly and reassembly during required maintenance.
- During extreme pressure drops, the WCM10 does not freeze up from rapid cooling and restricted flow and control.
- The Inline WCM10 Choke will produce little energy loss (pressure) drop when wide open. The inline configuration creates less pressure drop than an angled design. The streamlined flow of the multiple orifice valve choke action also means less pressure drop.

**Weir Concepts offers technical consulting
and provides a total end to end solution.**

- The WCM10 Inline Choke design employs two matched discs, each featuring circular or Pie openings. These discs can be rotated relative to each other to create variable flow areas.
- The two (2) discs are diamond lapped to achieve mating surfaces with a tolerance near two light bands of flatness. Ensuring precise shutoff and flow regulation
- The WCM10 Inline Choke discs are tungsten carbide for applications with extreme erosion and/or very high pressure drop across the choke.
- Inline chokes are available in:
 - ▶ Threaded or flanged connections from 1" to 3" and can handle pressure to 5000psi or 2500 ansi
 - ▶ Temperatures from -50 to 250 °F,
 - ▶ API, ANSI, NACE standards met
 - ▶ End connections to fit a wide variety of requirements and can be fitted with a wide range of actuators; electric, hydraulic or pneumatic.

Model WCM10 INLINE CHOKE

1" through 2-1/16"

Maximum Rating: ANSI 1500, API 3000

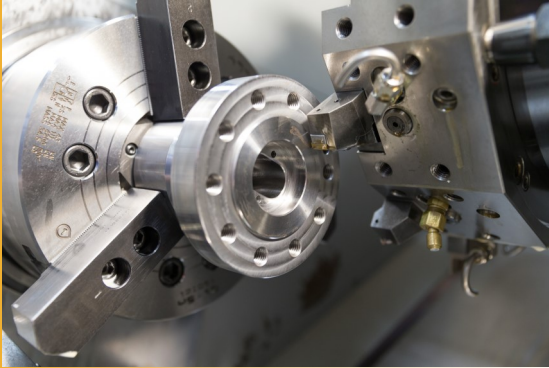

Trim Size		Flow Coefficient
No. of Holes	Diameter	CV (Max.)
1	1/8"	0.33
2	1/8"	0.70
1	1/4"	1.60
2	1/4"	3.33
1	1/2"	6.85
2	1/2"	13.50
2	5/8"	22.00

Valve pressure rating for specific configurations could be less depending on end connections, valve style and use of tungsten carbide trim.

CV values given in table above are subject to variation depending on valve end connections and options such as wear sleeves and back pressure beans.

Holes are pie shaped on 5/8"

WCM10 Flow Curves

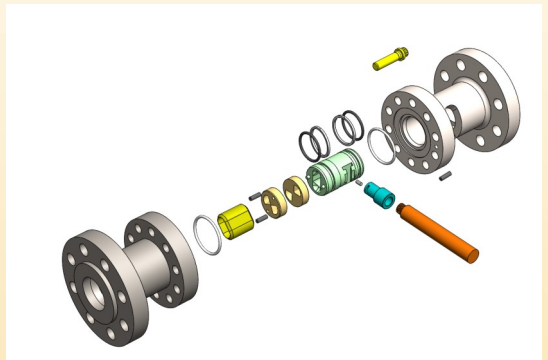
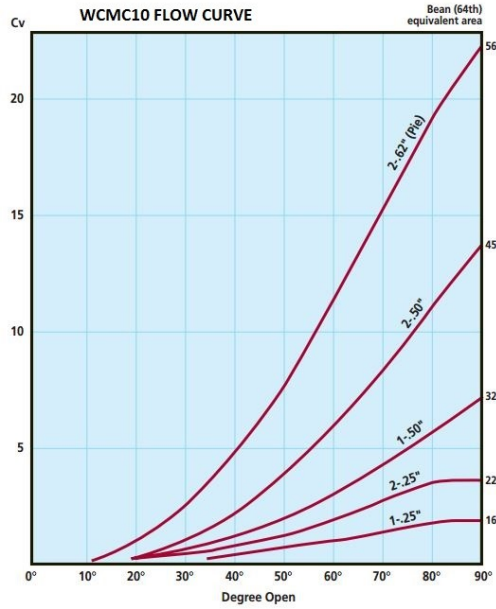

WC Choke Part # Matrix

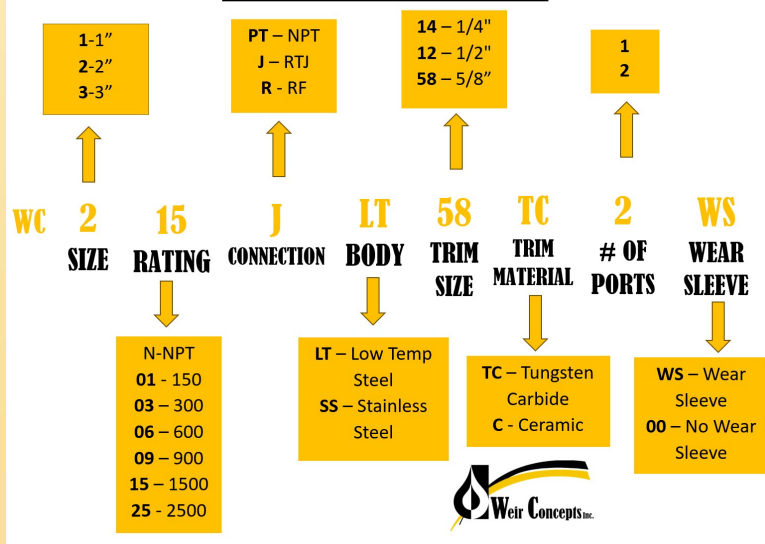

Weir Concepts at work for you

PRODUCT GUIDE

WEIR CONCEPTS WCM₁₀ INLINE CHOKE

Model WCM10 INLINE CHOKE 1"through 2-1/16"

Maximum Rating: ANSI 2500 API 5000

Item No.	Description	Qty.	Standard Material
1	Outlet Hub	1	4130 / 316SS / A350 LF2
2	Capscrew	10	L7M
3	Dowel Pin	1	Stainless Steel
4	Dowel Pin	2	Stainless Steel
5	O-Ring	1	Teflon
6	Front Disc	1	Tungsten Carbide
7	Back-Up Ring	2	Teflon
8	Rotor	1	Stainless Steel
9	O-Ring	1	Teflon
10	Drive Screw	2	Stainless Steel
11	Calibration Band	1	Stainless Steel
12	Handle	1	Stainless Steel
13	Handle Adapter	1	Stainless Steel
6	Back Disc	1	Tungsten Carbide
15	O-Ring	2	HSN
16	Wear Sleeve	1	Tungsten Carbide
17	Set Screw	1	ASTM AQ320
18	Rotor Hub	1	4130 / 316SS / A350 LF2

WCM10 INLINE CHOKE PARTS LIST

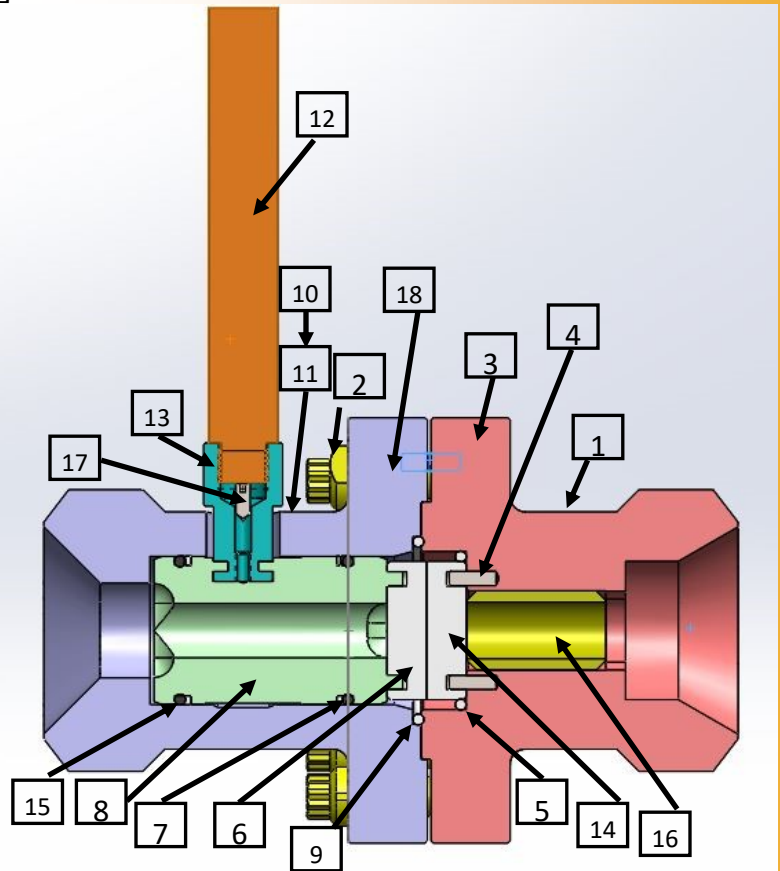

SOLUTIONS FOR YOUR COMPANY NEEDS

- HELP DESK -

FOR YOUR SUPPORT AND SERVICE

24 hours a day, 7 days a week

NO CHARGE ON CALLS SERVICE

We offer technical assistance, product knowledge, and reliable trouble shooting

Brochures/Maintenance info available online www.weirconcepts.com

HELP DESK EXPERTISE PROVIDED AT WEIR CONCEPTS

7596 Wagner RD NW

Edmonton, Alberta

CANADA T6E 5B2

780.462.1910 ph

780.462.1959 fax

info@weirconcepts.com

www.weirconcepts.com

Version 3.0

